



PRESENCE SENSOR - 360° MINI MICROWAVE



DESIGNED BY AUSTRALIANS, FOR AUSTRALIA

SUMMARY

The MATElec Australia FMS-13600 is an addition to our range of microwave sensors, and can be incorporated in any of the LED Batten range, to give sensor operation.

SPECIFICATIONS

Detection Angle:	360°
Detection Range:	8m Max
Switching Capacity:	1200W Incandescent, 300W Fluro
Time Delay:	10 sec - 12 min
Lux Adjustment:	Dawn - Dusk(3-2000Lux)
Voltage:	220V - 240V AC, 50Hz
Colour:	White
Warranty:	2 years

INSTALLATION

Exceeding the maximum rated load may cause overheating and cause the sensor to fail. Please exercise care.

All electrical connections relating to this installation must be undertaken by a suitably qualified and registered electrician, in accordance with Australian Standards.

1. Switch off main power.
2. Fix the bottom of the sensor to the desired position via the screw holes at the side of the sensor. (Fig 1)

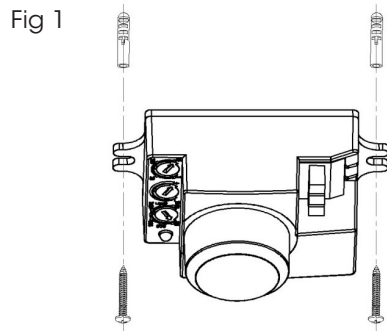

3. Wire up the sensor as per wiring diagram. (Fig 2)

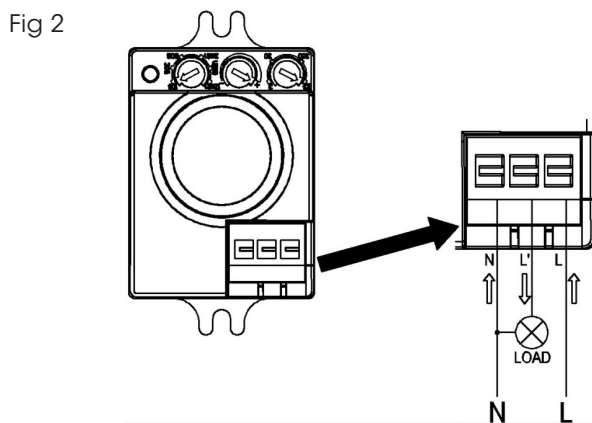

4. Switch back on mains power to test.
5. Turn the LUX knob clockwise, to the MAX setting (sun.) Turn the SENS knob clockwise to the MAX setting (+.) Turn the TIME knob anti-clockwise to the MIN setting (10s). (Fig 3)

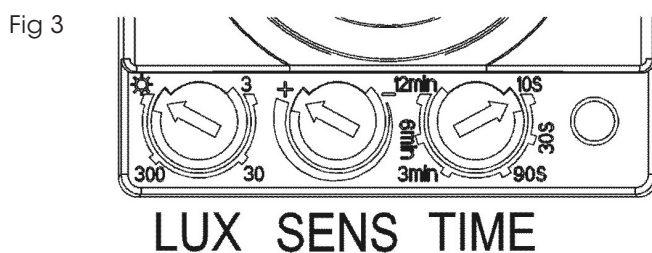

6. When you switch on the power, the light will be immediately turned on. It will turn off 10 sec later. Once the sensor detects presence from this point, it will operate as normal.
7. If the sensor detects further presence, after the initial trigger, time delay will start from the second trigger.
8. Turn the LUX knob anti-clockwise to the minimum (3.) If the ambient light is less than 3 LUX, the light will operate when it receives the induction signal.
9. When testing the unit in daylight, turn the LUX knob to the max SUN position.